



Using ON Semiconductor Constant Current Regulator (CCR) Devices in AC Applications

Prepared by: Mike Sweador

APPLICATION NOTE

Introduction

LEDs for AC and DC lighting pose a challenge to lighting designers. Technology for High Brightness (HB) LEDs is rapidly advancing. There are several existing solutions to drive these devices: Switching power devices (buck, boost, and buck-boost), linear regulators and resistor bias circuits. Each has its merits and drawbacks. One thing is common to all. LEDs need to be driven by a constant current source for maximum efficiency (lumens per watt), color and lifetime.

Switching regulator topology can be costly, cause EMI, and require additional circuit elements. Linear regulator circuits are less costly; but, may require additional components and are less efficient. Resistor bias is the least expensive method to set a current for a specific voltage. The drawback is that the current changes with a change in input voltage.

ON Semiconductor has developed a family of cost effective Constant Current Regulators (CCR) that will simplify circuit design while meeting the consensus requirement to keep the LED under a constant current condition.

The CCR can be represented as a variable resistor. As the voltage increases across the device, the internal resistance of the CCR increases to maintain a current close to the specification (I_{reg}). The CCR also has a negative

temperature coefficient, thus as power is dissipated by the CCR (increased temperature), its internal resistance increases causing a reduction in current. The CCR has a higher regulating current when pulsed compared to that at a steady state DC current because the die has not reached thermal stability.

The rectified AC waveform is similar to a pulsed signal. The regulating current will change as the power dissipation changes.

The purpose of this paper is to explore the utilization in AC lighting applications with 110 V, and 220 V AC rms input for CCR devices in the SOT-223 package. Using a 30 mA steady state CCR in an AC application results in 22 mA rms due to pulsed operation from full wave bridge rectification. This paper describes applications from new to retrofit circuit designs. The operating range of the CCR in AC circuits is from 1.8 V to 45 V. See appendix B for terms used in AC analysis.

The LED on time will depend on the forward voltage drop of the LED string. In the circuits referenced in this application, the CCR on time is about half the peak voltage on time. Thus the LEDs are on for about 50% of the time. The rms current through the LEDs is therefore about 50% of the regulating current.

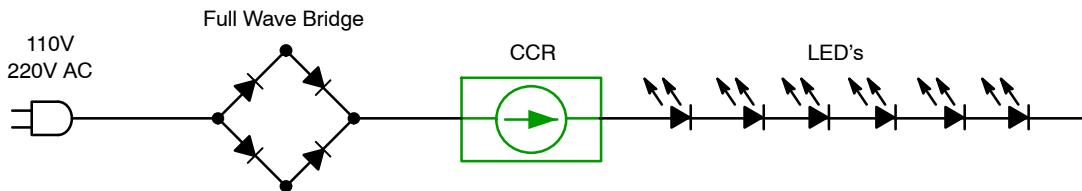

Figure 1. Basic AC Application

AND8433/D

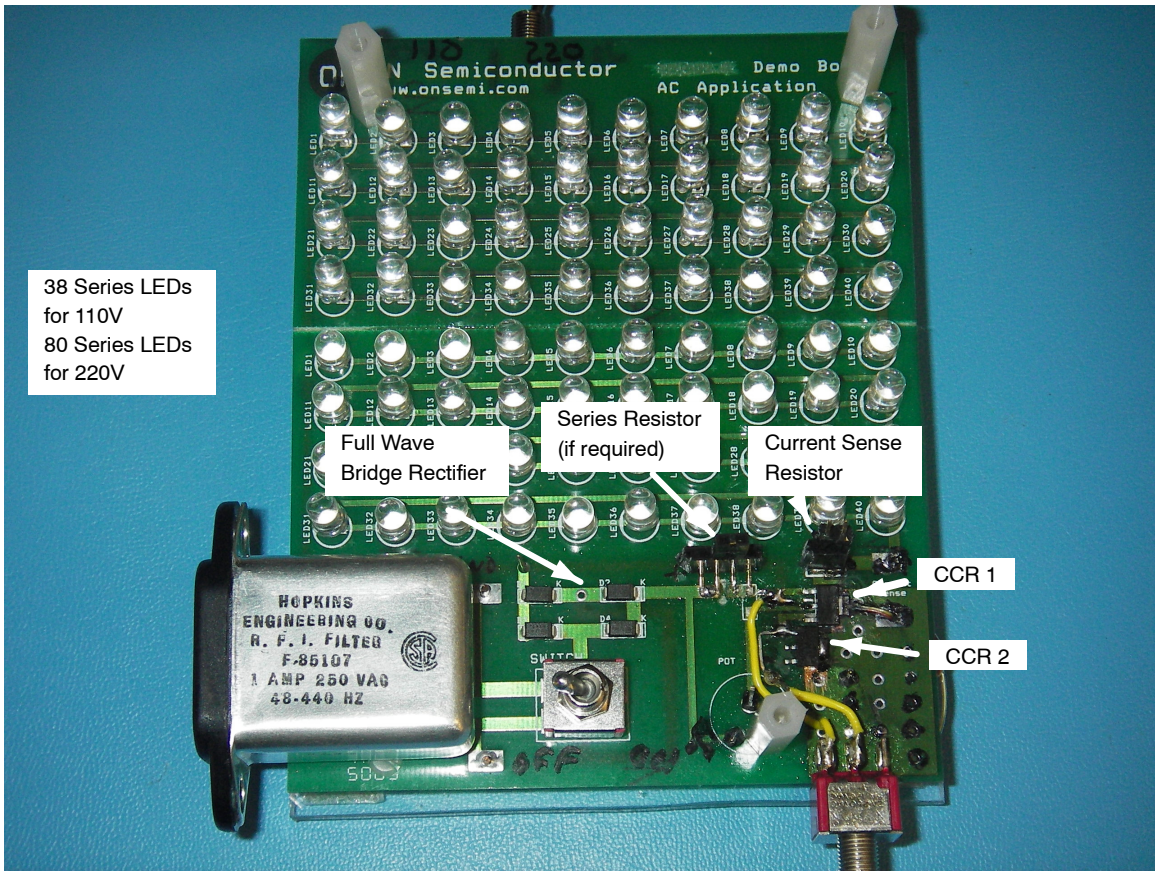

Figure 2. Demonstration PCB used for 110 V & 220 V AC rms analysis

DESIGN EXAMPLE 1: New Design with a CCR

This design selects the number of series LEDs.

Design parameters: 110 VAC rms, +/- 10%, HB LEDs (V_F of 3.3 V at 20 mA).

Analysis for Vin = +10% (max)

To calculate the number of LEDs for Vin Maximum = (110 V rms + 10%) = 120 V rms

Rectified V_{peak} = 120 V rms x 1.414 = 170 V

V_F of LED string = 170 V (peak Vin) – 45 V (V_{ak} max) = 125 V (V_F led string)

of LEDs = 125 V / 3.3 V = 38 LEDs

Analysis for Vin = -10% (min)

Testing for minimum Vin: (110 Vrms – 10%) = 100 Vrms

Rectified V_{peak} = 100 Vrms x 1.414 = 141 V (peak Vin)

CCR V_{ak} is: 141 V (peak Vin) – 125 V (V_F LED string) = 16 V

The V_{ak} range will vary with the number of LEDs in the string. Adding 3 additional LEDs will set the V_{ak} range from 6 V to 35 V. The additional HB LEDs provides greater luminosity and reduces CCR thermals.

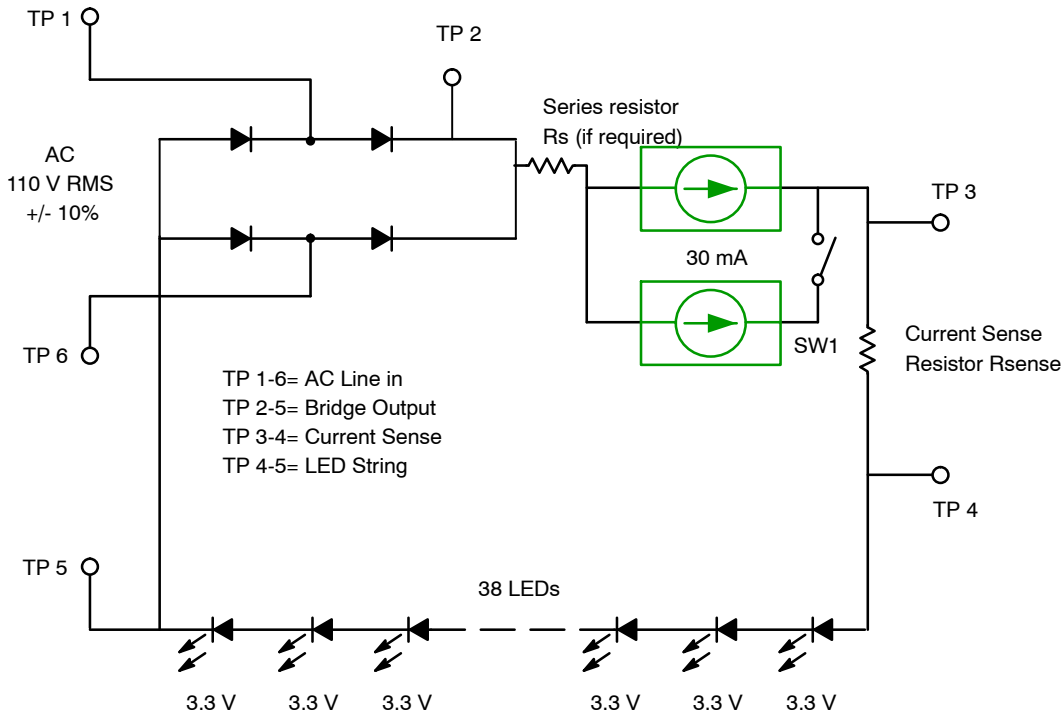

Figure 3. Direct AC Line LED Circuit with CCR

The AC rms voltage is full wave rectified into pulsating DC at a frequency of 120 Hz. The CCR turns on when the voltage exceeds the V_F for the LEDs and the bridge rectifier, controlling the current and isolating the LEDs from the peak rectified voltage.

Thermal Analysis of Design Example 1

(120 VAC, 38 LEDs)

The power dissipation of the CCR for Figure 3 is determined by:

$$(V_{ak\ rms}) \times (I_{REG} \times \text{Duty Cycle})$$

$$V_{ak\ rms} = V_{bridge\ rms} - \text{LED string } V_{F\ rms}$$

$$(120\ V_{br\ rms} - (38 \times 3.3\ V\ LED \times 0.707)) \times (30\ mA \times 50\%) = 31\ V\ rms \times 15\ mA = 465\ mW$$

A SOT-223 with a 100 mm² 1 oz Cu heat spreader will operate up to 85°C.

The data sheet power dissipation tables show various combinations for other ambient temperatures.

The following oscilloscope traces (Figures 4, 5 and 6) are for a 110 V ±10% AC rms input with 38 LEDs in series. The regulated current is measured by using a 100 Ω, 1% sense resistor. The measurements show the rms voltage across the sense resistor with the rms current below the voltage measurement. The circuit is similar to Figure 3 using a single NSI45030AZT1G 30 mA CCR. The heatsink for the CCR on this test PCB is 500 mm².

All waveforms were taken using differential voltage probes.

AND8433/D

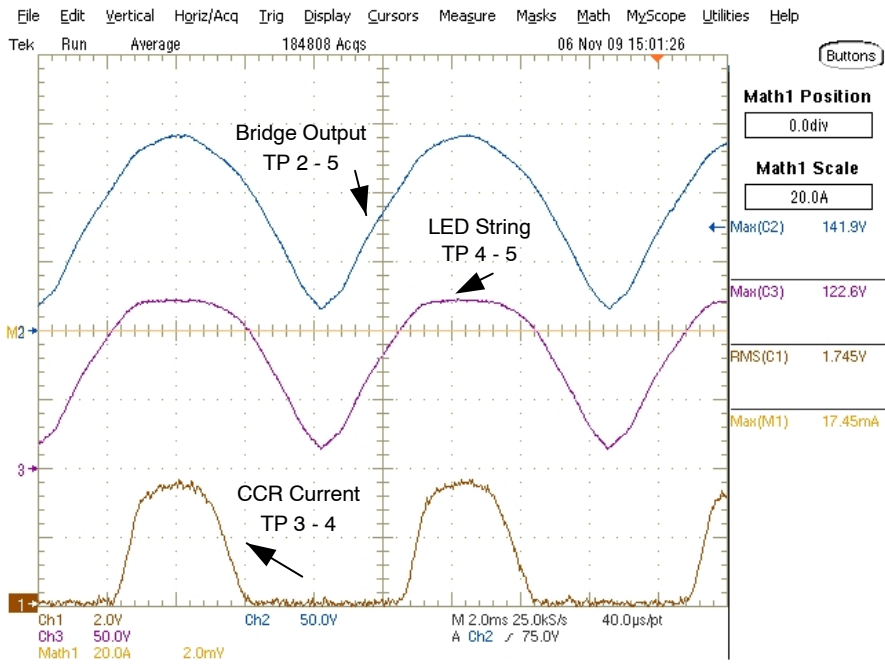

Figure 4. 100 V rms 1 x 30 mA CCR Analysis

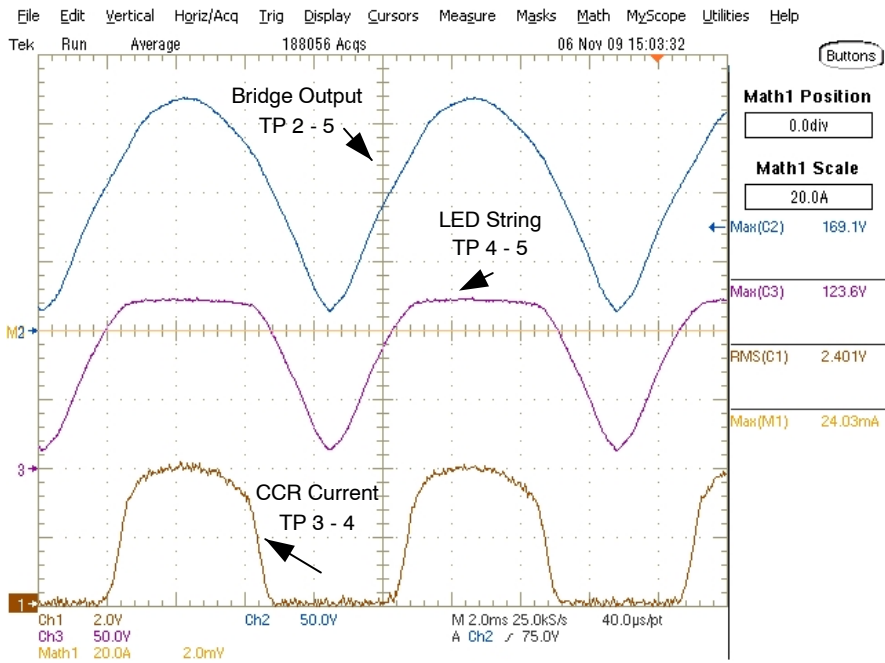

Figure 5. 120 V rms, 1 x 30 mA CCR Analysis

AND8433/D

CCRs can be operated in parallel to increase the regulated current supplied to the circuit. The waveforms of Figure 6 were taken with two 30 mA CCRs operated in parallel (Figure 3, SW 1 closed).

The LED intensity is increased when the supplied current is doubled. The LED V_F increases by less than 10% with a 100% increase in drive current.

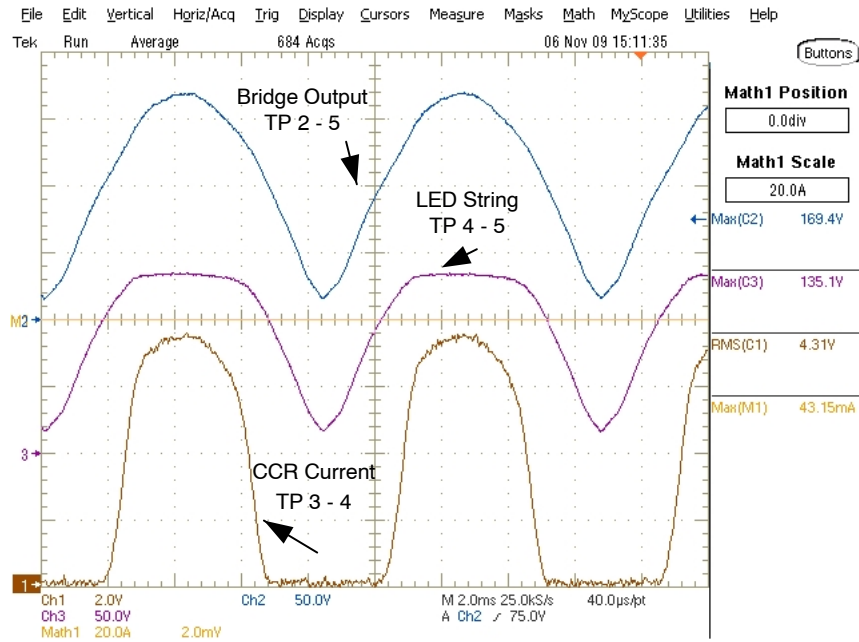

Figure 6. 120 V rms, 2 x 30 mA CCR Analysis

In summary for 110 VAC operation:

Table 1

Vin AC V rms	V rectified V Peak	CCRs	CCR Ireg mA rms	V_F LED String VPeak	Vak CCR VPeak
100	141	1 CCR	18	123	18
110	156	1 CCR	21	124	32
120	170	1 CCR	24	124	46
120	170	2 CCRs	43	135	34

AND8433/D

220 V AC ANALYSIS

All that is required to use a CCR at 220 V AC rms are additional LEDs.

The following oscilloscope traces were taken on a similar circuit to Figure 3 operating at 220 V AC rms with 80 LEDs in series:

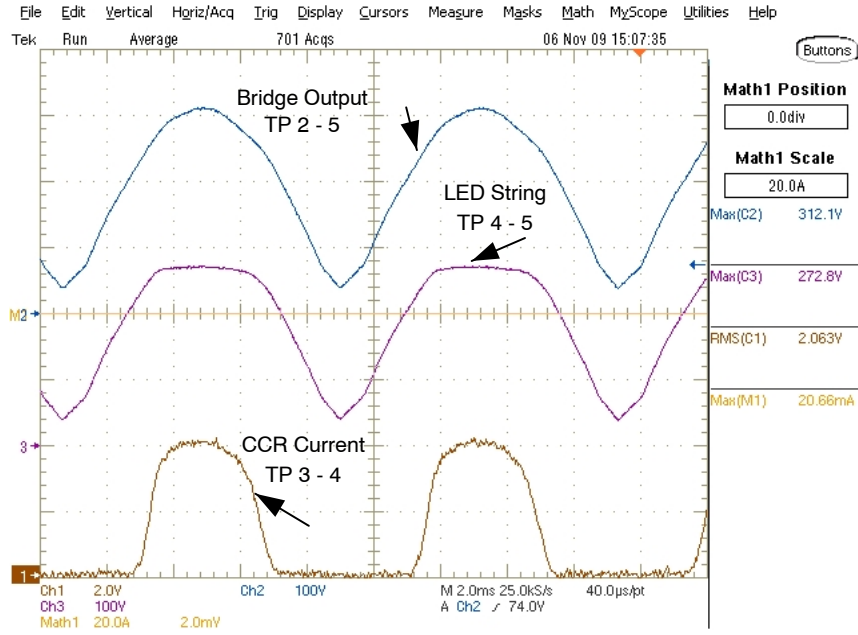

Figure 7. 220 V rms, 1 x 30 mA CCR Analysis

AND8433/D

DESIGN EXAMPLE 2: Retrofitting using a CCR (Figure 8)

Design parameters: 110 V AC rms, +/- 10%, existing design using 24 LEDs (V_F of 3.3 V at 22 mA)

A series dropping resistor (R_s) will be chosen to keep the CCR within its operating limits.

Rectified V_{peak} (maximum) = 120 V rms x 1.414 = 170 V

V_F of LED string = 24 x 3.3 V = 79.2 V

The voltage drop required is: $V_{peak} - (V_F \text{ leds pk} + V_{ak} \text{ CCR pk} + V_{Rsense \text{ pk}})$

V drop of $R_s = 170 \text{ V} - (79.2 \text{ V} + 45 \text{ V} + 4) = 41.8 \text{ V}$

CCR pk current is 34 mA; therefore, $R_s = 41.8 \text{ V} / .034 \text{ A} = 1229 \Omega$ (circuit tested with 1200 Ω R_s)

The power dissipation is $V \times I = 1.42 \text{ W pk}$ or 1.0 W RMS.

Testing for minimum V_{in} : 110 V rms x 0.9 = 100 V rms using a 1200 Ω R_s

Rectified $V_{peak} = 100 \text{ Vrms} \times 1.414 = 141 \text{ V}$

CCR V_{ak} is $141 \text{ V} - (79.2 + 41.8 + 4) = 16 \text{ V}$

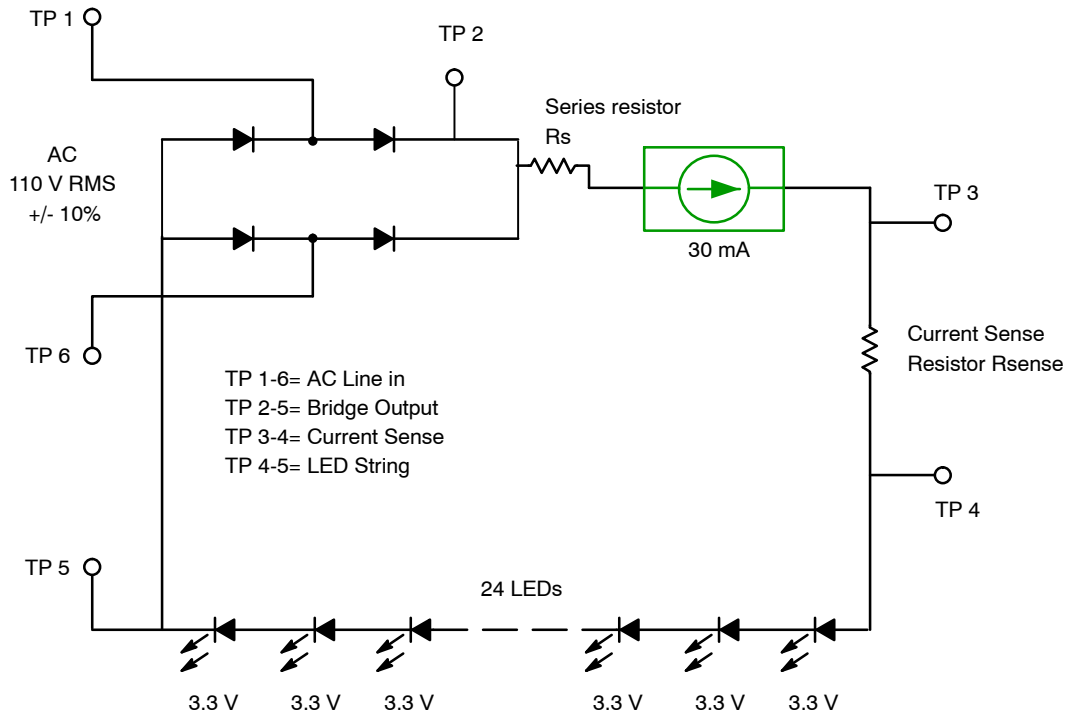

Figure 8. Direct AC Line LED Circuit with CCR

AND8433/D

24 LEDs, 1200Ω Rs, 1 CCR, 100 Ω Rsense, 25°C

TDS5104B Oscilloscope Measurements	Max	rms		Max	rms
Bridge output	141	98	VLEDs	80	64
VRs+Vak+VRsense	61	34	VRsense	3.6	2.1
VRs+Vak	57.4	31.9	Vak	15.6	6.5
VRs	41.8	25.4	VRs	41.8	25.4
Bridge output	155	107	VLEDs	80.8	65
VRs+Vak+VRsense	74.2	42	VRsense	3.9	2.4
VRs+Vak	70.3	39.6	Vak	26.3	11.6
VRs	44	28	VRs	44	28
Bridge output	171	117	VLEDs	81.7	65.6
VRs+Vak+VRsense	89.3	51.4	VRsense	3.9	2.8
VRs+Vak	85.4	48.6	Vak	39	18
VRs	46.4	30.6	VRs	46.4	30.6

Actual 24 LED, 1200Ω series resistor circuit measurements

Power Dissipation for 120V AC rms	Max	rms
I _{reg} A	0.039	0.028
P _D Rs (W)		0.8568
P _D CCR (W)		0.504
P _D Rsense (W)		0.0784
P _D LEDs (W)		1.8368
Total P _D (W)		3.276

Summary

The CCR can be represented as a variable resistor. As the voltage increases across the device the internal resistance of the CCR increases to maintain a current close to the specification (I_{reg}). The CCR also has a negative temperature coefficient, thus as power is dissipated by the CCR (increased temperature) the internal resistance is increased causing a reduction in current. This prevents thermal runaway and protects the LEDs increasing their life and reliability. The CCR has a higher regulating current when pulsed compared to that at a steady state DC current because the die has not reached thermal stability.

The rectified AC waveform is similar to a pulsed signal, the regulating current will change as the power dissipation changes.

The LED on time will depend on the forward voltage of the LED string. In the circuits referenced in this application it is about half the peak voltage and thus the LEDs are on for about 50% of the time. The rms current through the LEDs is therefore about 50% of the regulating current.

Appendix A

SOD-123 devices are:

NSI50010YT1G, Steady State $I_{REG} = 10 \text{ mA} \pm 30\%$

NSI45020T1G, Steady State $I_{REG} = 20 \text{ mA} \pm 15\%$

NSI45025T1G, Steady State $I_{REG} = 25 \text{ mA} \pm 15\%$

NSI45030T1G, Steady State $I_{REG} = 30 \text{ mA} \pm 15\%$

NSI45020AT1G, Steady State $I_{REG} = 20 \text{ mA} \pm 10\%$

NSI45025AT1G, Steady State $I_{REG} = 25 \text{ mA} \pm 10\%$

NSI45030AT1G, Steady State $I_{REG} = 30 \text{ mA} \pm 10\%$

SOT-223 devices are:

NSI45025ZT1G, Steady State $I_{REG} = 25 \text{ mA} \pm 15\%$

NSI45030ZT1G, Steady State $I_{REG} = 30 \text{ mA} \pm 15\%$

NSI45025AZT1G, Steady State $I_{REG} = 25 \text{ mA} \pm 10\%$

NSI45030AZT1G, Steady State $I_{REG} = 30 \text{ mA} \pm 10\%$

NSI50020DZT1G*, Adjustable from 20 mA to 40 mA

NSI50035DZT1G*, Adjustable from 35 mA to 70 mA

DPAK devices are:

NSI50060DDT1G*, Adjustable from 60 mA to 100 mA

NSI50090DDT1G*, Adjustable from 90 mA to 160 mA

* Products pending release

Appendix B:

For AC (Alternating Current) analysis of series LED circuits, we will be using the following terms:

V_{in} = The input AC Line voltage applied expressed as rms or Stepped down with a transformer.

V_{peak} = Highest V_{in} with a sinusoidal voltage ($V_{in} \times 1.414$)

$V_{bridge \text{ rms}}$ = $V_{peak} \times 0.707$

$V_{F \text{ rms}}$ = $V_{F \text{ LED}} \times 0.707$

R_s = series dropping resistor if required.

R_{sense} = series resistor to measure current. V measured / 100Ω , 1% resistor = current

I_{reg} = regulated circuit current

$I_{reg \text{ rms}}$ = $I_{reg \text{ peak}} \times \text{duty cycle}$ (approximately 50%).

Reference to Data Sheet:

The data sheet describes the devices and defines the following terms that will be used throughout this note:

V_{ak} = Voltage applied between the Anode and Cathode of the device.

P_D = Device power dissipation, typically in W.

T_A = Ambient Temperature in $^{\circ}\text{C}$

T_J = Device Junction Temperature in $^{\circ}\text{C}$

ON Semiconductor and  are registered trademarks of Semiconductor Components Industries, LLC (SCILLC). SCILLC reserves the right to make changes without further notice to any products herein. SCILLC makes no warranty, representation or guarantee regarding the suitability of its products for any particular purpose, nor does SCILLC assume any liability arising out of the application or use of any product or circuit, and specifically disclaims any and all liability, including without limitation special, consequential or incidental damages. "Typical" parameters which may be provided in SCILLC data sheets and/or specifications can and do vary in different applications and actual performance may vary over time. All operating parameters, including "Typicals" must be validated for each customer application by customer's technical experts. SCILLC does not convey any license under its patent rights nor the rights of others. SCILLC products are not designed, intended, or authorized for use as components in systems intended for surgical implant into the body, or other applications intended to support or sustain life, or for any other application in which the failure of the SCILLC product could create a situation where personal injury or death may occur. Should Buyer purchase or use SCILLC products for any such unintended or unauthorized application, Buyer shall indemnify and hold SCILLC and its officers, employees, subsidiaries, affiliates, and distributors harmless against all claims, costs, damages, and expenses, and reasonable attorney fees arising out of, directly or indirectly, any claim of personal injury or death associated with such unintended or unauthorized use, even if such claim alleges that SCILLC was negligent regarding the design or manufacture of the part. SCILLC is an Equal Opportunity/Affirmative Action Employer. This literature is subject to all applicable copyright laws and is not for resale in any manner.

PUBLICATION ORDERING INFORMATION

LITERATURE FULFILLMENT:

Literature Distribution Center for ON Semiconductor
P.O. Box 5163, Denver, Colorado 80217 USA
Phone: 303-675-2175 or 800-344-3860 Toll Free USA/Canada
Fax: 303-675-2176 or 800-344-3867 Toll Free USA/Canada
Email: orderlit@onsemi.com

N. American Technical Support: 800-282-9855 Toll Free USA/Canada
Europe, Middle East and Africa Technical Support:
Phone: 421 33 790 2910
Japan Customer Focus Center
Phone: 81-3-5773-3850

ON Semiconductor Website: www.onsemi.com

Order Literature: <http://www.onsemi.com/orderlit>

For additional information, please contact your local Sales Representative